

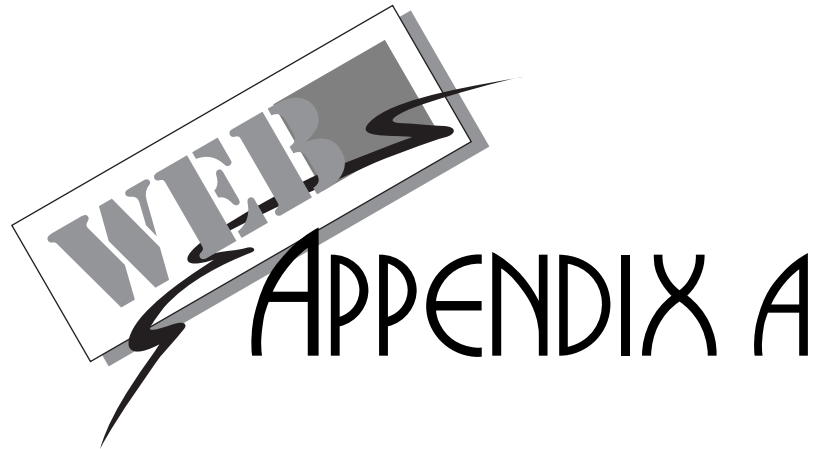

# WEB REFERENCE

- Aronson, L. (1994). HTML Manual of Style. Emeryville, CA: Ziff-Davis.
- Baczewski, P. (1996). An Introduction to the Internet in Higher Education. Article from <http://pcb2.acs.unt.edu/>.
- Langa, F. (1996). Seven deadly sins. Windows Magazine, 7(6), 11, 14.
- Shirk, H. N. (1996). Basic WWW Authoring Workshop. Denton, TX: University of North Texas. (05/15/96)
- Smith, R. J.; Gibbs, M.; & McFedries, P. (1995). (3ed.) Navigating the Internet. Indianapolis, IN: Sam.net.
- Tolhurst, W. A.; Pike, M. A.; Blanton, K. A.; & Harris, J. R. (1994). Using Internet, Special Edition. Indianapolis, IN: QUE.
- Will-Harris, D. (1996). Your Place in Cyberspace: the ABCs of building your own web site. Article from WWW.CNET.COM.





## INTERNET ADDRESSES

In order to navigate the Internet, one must understand the format of Internet addresses. All communication on the Internet involves a specific sequence of letters and symbols. The following is an example of an Internet address:

**tcetinfo@www.tcet.unt.edu.us**

The Internet address functions similarly to a postal address. The section before the @ sign indicates the *user id*. The characters after the @ sign is called the *domain*. It contains abbreviations with periods separating each *level* of the domain.

In the above example, the highest level begins at the far right and houses two letters that indicates a country. For example, US indicates the United States. UK stands for England; JP, for Japan; DE, for Germany; and TH, for Thailand. In the United States, the country code is *usually* not included.

Moving to the left inwardly on the address line, the next highest level (which is often first in the United States) is a code indicating the *type* of organization to which domain belongs. The following are different organization domains.

EDU	Education
COM	Commercial
NET	Network
ORG	Organization
GOV	Government
MIL	Military

The next group of letters, abbreviations, or words indicate an organization or company. In the example, the letters *unt* stands for the University of North Texas. Extra groups of letters may indicate subgroups within that organization. In the example, *coe.unt*, represents the College of Education within the university.

Some Internet e-mail addresses of a few famous people are listed below.

Bill Clinton	president@whitehouse.gov
Al Gore	vice-president@whitehouse.gov
Rush Limbaugh	70277.2502@compuserve.com
Bill Gates	billg@microsoft.com

## WORLD WIDE WEB ADDRESSES

The Uniform Resource Locator (URL) for the Web contains several elements. The *http://* prepares the browser to load a Web document. The domain name occupies the next position. Domain names are exactly the same as the domain part of the e-mail address described above. The remainder of the address (if used) will indicate a specific directory and/or file at that site. For example:

***http://www.tcet.unt.edu***

*http://* shows that the browser will retrieve and load a document written in HTML.

*www.tcet.unt.edu* shows the Web address of the Texas Center for Educational Technology at University of North Texas.  
This will load the default document at that site.

***http://www.unt.edu/~ic09/resume.html***

*http://* shows that the browser will retrieve and load a document written in HTML.

*people.unt.edu/* shows the Web address of University of North Texas.

*~ic09/* shows the account name of a person, organization, or department.

*resume.htm* loads a specific file in that directory or account listed above.



# APPENDIX B

## SITES

A collection of Web sites of interest to educators and educational Web developers are listed below. Because the World Wide Web is interactive and ever changing, these addresses change. If a favorite Web site is lost, search engines can be used to locate the new address or find similar sites. See page 18 for a discussion of search engines.

### Search Engines

Yahoo

<http://www.yahoo.com/>

Lycos, Inc.

<http://www.lycos.com/>

Web Crawler

<http://www.crawler.com/>

Excite

<http://www.excite.com/>

InfoSeek

<http://www3.infoseek.com/home/>

Virtual Library

<http://www.w3.org/hypertext/DataSources/bySubject/Overview.html>

W3 Catalog

<http://cuiwww.unige.ch/w3catalog/>

## Educational Software

Jumbo

<http://www.jumbo.com/pages/education/>

Oakland University Software Repository

<http://oak.oakland.edu/>

Shareware.com

<http://www.shareware.com/>

Ziff-Davis Software Library

<http://www.htofiles.com/home.html>

## Web software

NCSA Software tools

<http://www.ncsa.uiuc.edu/SDG/Software/SDGSoftDir.html>

U-M Software Archives

<http://www.umich.edu/~archive/>

TUCOWS - great rating system

<http://www.texoma.com/mirror/tucows/>

University of Texas Mac Archive

<http://wwwhost.ots.utexas.edu/mac/main.html>

Winsock Archive

<http://www.webcom.com/~llarrow/winsock.html>

## Web tutorials and help

Writing HTML - designed for teachers and can be downloaded

<http://www.mcli.dist.maricopa.edu/tut/>

Web 66 - project that helps schools set up Web sites

<http://web66.coled.umn.edu/>

HTML Crash Course

<http://www.nashville.net/~templedf/crash/CrashCourse.html>

Creating HTML - A Simple Guide

<http://www.netusa1.net/~jbornema/html.html>

The Bare Bones Guide to HTML- just the basics

<http://www.werbach.com/barebones/>

## Texas Educational Sites

Texas Center for Educational Technology  
<http://www.tcet.unt.edu/>

Texas Education Agency  
<http://www.tenet.edu/>

Texas Education Agency  
<http://www.tea.state.tx.us:70/>

## Lesson Plans and Resources

Ask ERIC - Educational Resource Information Center  
<http://ericir.syr.edu/>

Buzy Teacher's Website  
<http://www.ceismc.gatech.edu/BuzyT/>

Classroom Connect  
<http://www.classroom.net/>

Curriculum Web  
<http://www.curriculumweb.org/cw/>

Educational Online Sources  
[http://archive.phish.net/eols/web\\_image.html](http://archive.phish.net/eols/web_image.html)

EdWeb (Educational information about the internet)  
<http://k12.cnidr.org:90/>

Electronic Emissary (information about Internet projects)  
<http://www.tapr.org/emissary/>

Global School Project  
<http://k12.cnidr.org/gshwelcome.html>

Teachers.net  
<http://www.teachers.net/>

World Lecture Hall (Accounting to Zoology)  
<http://www.utexas.edu/world/lecture/index.html>



# WEB APPENDIX C

## EXAMPLES OF VISUAL CHART DESIGNS

### A. BALANCED DESIGN

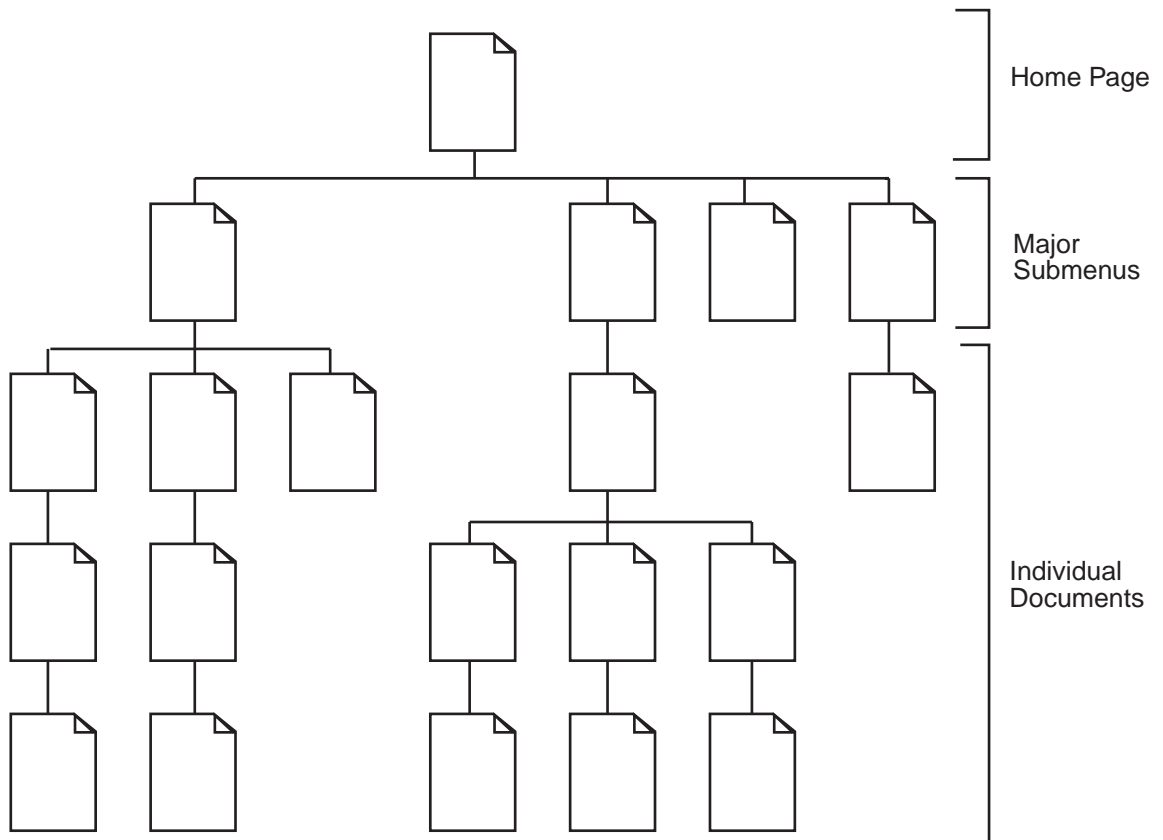

## B. DEAD END DOCUMENT

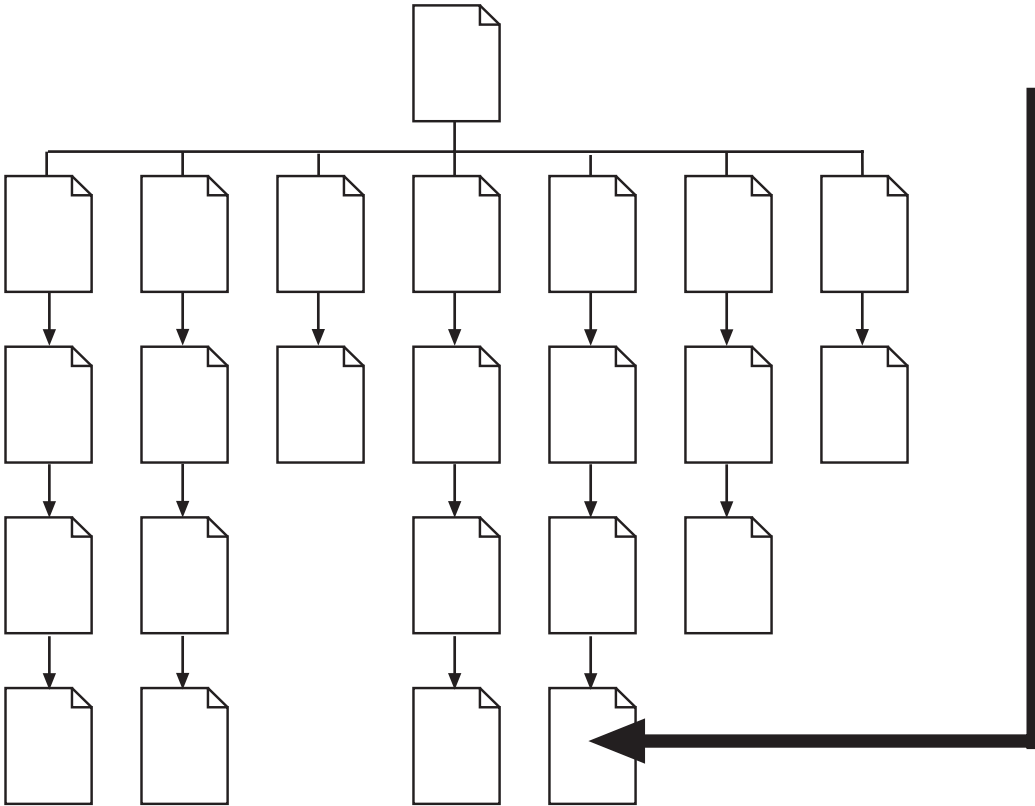

### DEAD END DOCUMENT

This reader has entered a site rich with structure and information, but will never see that because this document is a "dead end," without links to the local site or home page.

## C. TOO SHALLOW

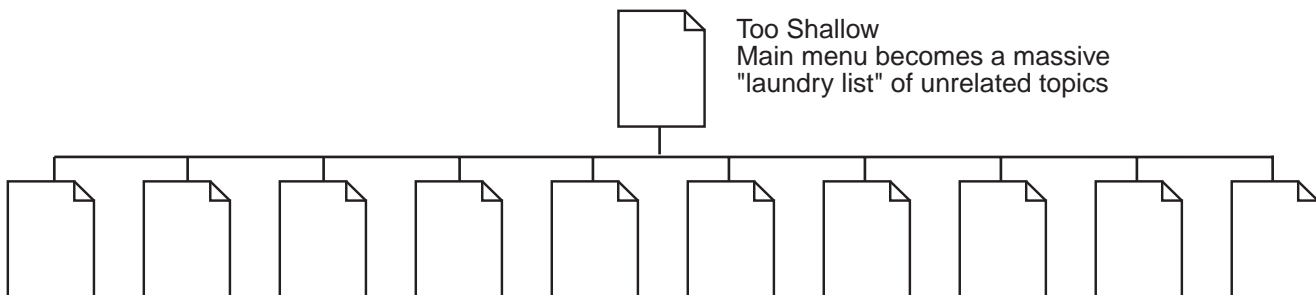

## D. TOO DEEP

